

Item	Description	Material	Item	Description	Material
1	Rotary O Ring	Viton® / EPR / Kalrez® / Aflas®	9	Clamp Ring	316L Stainless Steel
2	Sleeve O Ring	Viton® / EPR / Kalrez® / Aflas®	10	Drive Screws	Stainless Steel
3	Sleeve	316L Stainless Steel	11	Clip Screws	Stainless Steel
4	Springs	Alloy 276	12	Setting Clips	Brass
5	Rotary Face	Sic	13	Anti-tamper Screws	Stainless Steel
6	Stationary Face	316L SS - Carbon / SiC	14	Gasket	AF1 / GFT
7	Stationary O Ring	Viton® / EPR / Kalrez® / Aflas®	15	R' Bush O Ring	Viton® / EPR / Kalrez® / Aflas®
8	Gland	316 Stainless Steel	16	Restriction Bushing	Carbon

SISSTM - Dimensional Information (mm)

	A	B	C	D	E	ØF Min	F Max	ØG Min	ØG Max	ØH Max	I	J	M	N	O	P	Q	R
24	104.8	57.2	-	23.8	41.0	48.6	71.2	92.8	12	28.2	38.3	15.0	71.4	10	1/4NPT	17.9	79.1	
25	104.8	57.2	-	23.8	41.0	48.6	71.2	92.8	12	28.2	38.3	15.0	71.4	10	1/4NPT	17.9	79.1	
28	108.0	60.4	-	23.8	44.0	52.6	74.3	96.0	12	28.2	38.3	14.1	76.2	10	1/4NPT	17.0	82.6	
30	111.1	63.5	-	23.8	46.0	54.7	77.5	99.0	12	28.2	38.3	13.0	78.0	10	1/4NPT	17.8	84.1	
32	111.1	63.5	-	23.8	48.0	54.7	77.5	99.0	12	28.2	38.3	13.0	78.5	10	1/4NPT	17.8	84.1	
33	111.1	63.5	-	23.8	49.0	54.7	77.5	99.0	12	28.2	38.3	13.0	78.5	10	1/4NPT	17.8	84.1	
33K	98.5	63.5	-	21.7	49.0	54.7	77.5	86.5	12	27.7	36.8	13.7	82.5	15	1/4NPT	13.7	90.7	
35	111.1	66.7	-	23.8	51.0	58.6	80.7	99.0	12	28.2	38.3	13.0	78.5	10	1/4NPT	17.6	83.8	
38	127.0	72.0	-	21.7	58.0	63.6	85.9	115.0	12	28.0	36.8	12.7	85.7	10	1/4NPT	16.2	92.1	
40	127.0	72.0	-	21.7	60.0	64.7	85.9	115.0	12	28.0	36.8	12.7	85.7	10	1/4NPT	16.2	92.1	
43	133.4	76.8	-	21.7	63.0	68.6	90.8	121.3	12	28.0	36.8	13.0	89.7	10	1/4NPT	16.1	94.9	
43K	119.7	81.0	-	17.1	63.0	71.7	95.0	107.6	12	28.0	43.8	22.9	93.5	45	1/4NPT	18.9	101.6	
45	133.4	76.8	-	21.7	65.0	70.2	90.8	121.4	12	28.0	36.8	12.7	88.9	10	1/4NPT	16.1	95.3	
48	133.4	76.8	-	21.7	67.0	70.2	90.8	121.4	12	28.0	36.8	12.7	88.9	10	1/4NPT	16.2	95.3	
50	139.7	86.0	-	21.7	70.0	77.7	100.0	127.7	12	28.0	36.8	12.7	95.3	10	1/4NPT	16.2	101.6	
53	146.1	93.6	-	21.7	73.0	84.7	111.1	130.0	16	28.0	36.8	13.4	101.3	10	1/4NPT	16.2	108.0	
55	146.1	93.6	-	21.7	75.0	84.7	111.1	130.0	16	28.0	36.8	13.4	101.3	10	1/4NPT	16.2	108.0	
58	146.1	93.6	-	21.7	78.0	84.7	111.1	130.0	16	28.0	36.8	13.4	101.3	10	1/4NPT	16.2	108.0	
60	152.4	100.0	-	21.7	80.0	89.6	117.5	136.4	16	28.0	36.8	13.7	104.4	10	1/4NPT	16.2	114.3	
63	177.8	109.5	-	23.9	82.6	98.6	127.0	161.8	16	27.4	39.5	13.5	121.2	10	3/8NPT	18.8	126.8	
65	177.8	109.5	-	23.9	85.7	98.7	127.0	161.8	16	27.4	39.5	13.5	121.2	10	3/8NPT	18.8	126.8	
70	177.8	109.5	-	23.9	90.0	99.7	127.0	161.8	16	27.4	39.5	13.5	121.2	10	3/8NPT	18.8	126.8	
75	190.5	125.4	-	23.9	98.4	113.5	142.9	174.5	16	33.0	39.7	13.8	130.6	10	3/8NPT	18.5	137.2	
80	190.5	125.4	-	23.9	101.6	113.5	142.9	174.5	16	33.0	39.7	13.8	130.6	10	3/8NPT	18.0	138.1	
85	203.2	135.0	-	23.9	108.0	121.5	156.0	185.0	20	33.0	39.7	13.4	140.2	10	3/8NPT	18.9	146.0	

Note:- The 33K & 43K gland designs are specifically designed to suit the KSB CPK pump with Quench & Drain connections at different angular positions.

SISSTM - Dimensional Information (inches)

	A	B	C	D	E	ØF Min	F Max	ØG Min	ØG Max	ØH Max	I	J	M	N	O	P	Q	R
1.000	4.125	2.25	-	0.937	1.625	1.937	2.812	3.625	0.500	1.110	1.508	0.590	2.812	10	1/4NPT	0.705	3.115	
1.125	4.250	2.375	-	0.937	1.750	2.093	2.937	3.750	0.500	1.110	1.508	0.555	3.000	10	1/4NPT	0.705	3.250	
1.250	4.375	2.500	-	0.937	1.875	2.154	3.062	3.875	0.500	1.110	1.508	0.511	3.091	10	1/4NPT	0.700	3.312	
1.375	4.375	2.625	-	0.937	2.000	2.308	3.062	3.875	0.500	1.110	1.508	0.511	3.091	10	1/4NPT	0.693	3.300	
1.500	5.000	2.832	-	0.854	2.250	2.500	3.375	4.500	0.500	1.103	1.449	0.500	3.375	10	1/4NPT	0.638	3.625	
1.625	5.250	3.022	-	0.854	2.375	2.700	3.573	4.750	0.500	1.103	1.449	0.500	3.532	10	1/4NPT	0.638	3.737	
1.750	5.250	3.022	-	0.854	2.500	2.750	3.573	4.750	0.500	1.103	1.449	0.500	3.500	10	1/4NPT	0.634	3.750	
1.875	5.250	3.022	-	0.854	2.625	2.750	3.573	4.750	0.500	1.103	1.449	0.500	3.500	10	1/4NPT	0.638	3.750	
2.000	5.500	3.386	-	0.854	2.750	3.062	3.937	5.000	0.500	1.103	1.449	0.500	3.750	10	1/4NPT	0.638	4.000	
2.125	5.750	3.687	-	0.854	2.875	3.375	4.375	5.125	0.625	1.103	1.449	0.528	3.989	10	1/4NPT	0.638	4.250	
2.250	5.750	3.687	-	0.854	3.000	3.375	4.375	5.125	0.625	1.103	1.449	0.528	3.989	10	1/4NPT	0.638	4.250	
2.375	6.000	3.937	-	0.854	3.125	3.500	4.625	5.375	0.625	1.103	1.449	0.540	4.111	10	1/4NPT	0.638	4.500	
2.500	7.000	4.312	-	0.942	3.250	3.875	5.000	6.375	0.625	1.083	1.556	0.532	4.772	10	3/8NPT	0.741	4.993	
2.625	7.000	4.312	-	0.942	3.375	3.875	5.000	6.375	0.625	1.083	1.556	0.532	4.772	10	3/8NPT	0.741	4.993	
2.750	7.000	4.312	-	0.942	3.625	3.937	5.000	6.375	0.625	1.083	1.556	0.532	4.772	10	3/8NPT	0.741	4.993	
2.875	7.500	4.937	-	0.942	3.750	4.437	5.625	6.875	0.625	1.300	1.556	0.545	5.140	10	3/8NPT	0.742	5.375	
3.000	7.500	4.937	-	0.942	3.875	4.500	5.625	6.875	0.625	1.300	1.563	0.545	5.142	10	3/8NPT	0.728	5.402	
3.125	7.500	4.937	-	0.942	4.000	4.500	5.625	6.875	0.625	1.300	1.563	0.545	5.142	10	3/8NPT	0.709	5.438	
3.250	8.000	5.312	-	0.942	4.125	4.750	6.125	7.250	0.750	1.300	1.562	0.528	5.520	10	3/8NPT	0.734	5.750	
3.375	8.000	5.312	-	0.942	4.250	4.750	6.125	7.250	0.750	1.300	1.563	0.528	5.520	10	3/8NPT	0.744	5.750	

Original Instructions

Pre-Installation Checks.

- (i) Shaft Outside Diameter is within tolerance ± 0.002" (±0.05mm)
- (ii) Shaft run out < 0.004" (0.1mm) T.I.R.
- (iii) Shaft end float < 0.005" (0.13mm).
- (iv) Fluid seal can be obtained on the Stuffing Box face.
- (v) There are no sharp edges over which the seal 'O' Ring (2) must pass.

Installation instructions.

1. Lubricate the shaft with the grease provided.
2. Slide the seal onto the shaft.
3. Assemble rest of equipment in final running position.
4. Slide seal into position. Fit washers in all cases and tighten Gland Nuts down firmly.
5. Equally tighten the Drive Screws down onto the shaft.
6. Remove setting clips.
7. Spin the shaft by hand. Listen and feel for any shaft binding, etc.
8. Connect the flush connections. If flush connection is not required, please ensure that it is properly sealed with a 1/4"NPT plug.
9. Ensure the pump is primed prior to start up.
10. Retain clips and clip screws for future use.

EN

Übersetzung der Original-Anweisungen

Vormontagekontrollen

- (i) Der Wellenaußendurchmesser liegt innerhalb der Toleranzgrenzen von ± 0,002" (± 0,05mm).
- (ii) Wellenschlag < 0,004" (0,1mm) Ablesung über den gesamten Meßbereich
- (iii) Axialspiel der Welle < 0,005" (0,13mm)
- (iv) Erzielen einer Flüssigkeitsdichtung an der Stopfbuchsenfläche
- (v) Der dichtende O-Ring (2) darf über keine scharfen Kanten geführt werden.

Montageanleitungen

1. Welle mit dem vorgesehenen Fett schmieren
2. Dichtung auf die Welle schieben
3. Übrige Teile in Endstellung montieren.
4. Dichtung in die korrekte Position schieben. Stets Unterlegscheiben einbauen und Brillenmuttern fest anziehen.
5. Desgleichen die Halteschrauben fest auf der Welle anziehen
6. Zentrierclips entfernen
7. Welle per Hand drehen. Darauf achten, ob die Welle schleift, usw.
8. Falls der Spülanschluß nicht benötigt wird, ist es erforderlich, ihn mit einem Blindstopfen 1/4"NPT zu verschließen.
9. Sicherstellen, daß die Pumpe vor dem Anlauf entlüftet wird.
10. Clips und Justierschrauben für spätere Verwendung aufbewahren

DE

SISSTM
SINGLE STATIONARY SEAL

INSTALLATION INSTRUCTIONS

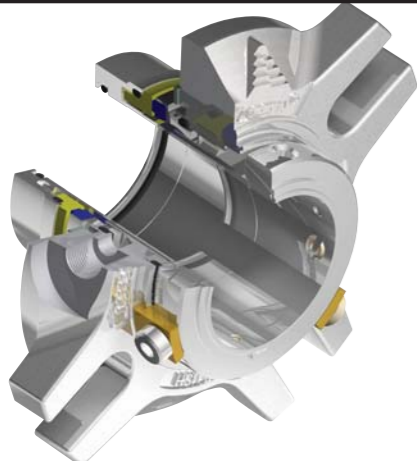

ENVIRONMENTAL TECHNOLOGY

AESSEAL plc
Mill Close,
Templeborough,
Rotherham,
South Yorkshire,
England, S60 1BZ.
Tel: +44 (0) 1709 369966
Fax: +44 (0) 1709 720788
www.aesseal.com

IT ES FR PT NL NO DK FI SE

Traduzione delle istruzioni originali	IT	Traducción de instrucciones originales	ES	Traduction de la notice originale	FR	Tradução de manual de instruções original	PT	Vertaling van de oorspronkelijke gebruiksaanwijzing	NL
<p>Controlli pre-installazione</p> <p>(i) Il diametro esterno dell'albero ha una tolleranza $\pm 0,002''$ ($\pm 0,05$ mm)</p> <p>(ii) Eccentricità dell'albero $< 0,004''$ (0,1 mm) T.I.R.</p> <p>(iii) Gioco assiale dell'albero $< 0,005''$ (0,13 mm)</p> <p>(iv) Si può ottenere la tenuta del fluido sulla faccia della camera stoppa.</p> <p>(v) Non ci sono bordi affilati su cui deve passare l' O-Ring (2) di tenuta.</p> <p>Norme d'installazione</p> <ol style="list-style-type: none"> Lubrificare l'albero con il grasso di silicone fornito. Fare scorrere la tenuta sull'albero. Montare il resto dell'apparecchiatura nella posizione finale di esercizio. Fare scorrere la tenuta in posizione. Inserire sempre le rondelle e stringere forte i dadi della flangia. Stringere in modo uniforme le viti di trascinamento sull'albero. Rimuovere le graffe di centraggio. Ruotare l'albero a mano. Sentire se vi sono eventuali inceppamenti dell'albero, ecc. Collegare i raccordi di flussaggio, raffreddamento e drenaggio. Se non richiede l'allacciamento di flussaggio, assicurarsi che la tenuta sia chiusa bene con un tappo NPT da 1/4". Assicurarsi che la pompa sia adescata prima dell'avviamento. Conservare le graffe e le viti delle graffe per impieghi futuri. 	<p>Comprobaciones antes de la instalación.</p> <p>(i) Diámetro exterior del eje dentro de una tolerancia de $\pm 0,05$ mm (0,002 plg).</p> <p>(ii) Descentramiento del eje $< 0,1$ mm (0,004 plg) (lectura total del indicador).</p> <p>(iii) Movimiento axial del extremo del eje $< 0,13$ mm (0,005 plg).</p> <p>(iv) Puede obtenerse un sellado del fluido en la cara de la cajera.</p> <p>(v) No hay cantos vivos sobre los que tenga que pasar la junta tórica (2).</p> <p>Instrucciones para la instalación.</p> <ol style="list-style-type: none"> Lubrique el eje con la grasa proveída. Corra el cierre sobre el eje. Monte el resto del equipo en la posición de funcionamiento final. Corra el cierre hasta su posición. Coloque arandelas en todos los casos y apriete firmemente las tuercas del prensaestopas. Apriete uniformemente los tornillos de transmisión en el eje. Quite las grapas de sujeción. Haga girar a mano el eje. Escuche y examine al tacto para comprobar si hay acuíamiento del eje, etc. Acople las conexiones de "flush", refrigeración y drenaje (si no se necesita el "Flush," asegure que está tapado bien con un tapón de 1/4" NPT). Verifique que la bomba está cebada antes de la puesta en marcha. Guarde las grapas con sus tornillos para uso futuro. 	<p>Contrôles avant montage.</p> <p>(i) Le diamètre extérieur de l'arbre est dans les limites de la tolérance de $\pm 0,05$ mm.</p> <p>(ii) Excentricité de l'arbre $< 0,1$ mm maximum - jeu radial.</p> <p>(iii) Jeu axial de l'arbre $< 0,13$ mm.</p> <p>(iv) On obtient l'étanchéité aux fluides au niveau de la face du presse-étoupe.</p> <p>(v) Éviter toute arête vive pour le passage du joint torique de la garniture (2).</p> <p>Instructions de montage.</p> <ol style="list-style-type: none"> Lubrifier l'arbre avec la graisse fournie. Faire coulisser la garniture sur l'arbre. Monter le reste des pièces en position définitive de fonctionnement. Glisser la garniture sur l'arbre. Toujours monter les rondelles et serrer les écrous de chapeau fermement. Serrer les vis d'entraînement de façon égale sur l'arbre. Retirer les attaches de réglage. Faire tourner l'arbre à la main. Écouter et sentir à la main si l'arbre grippe. Raccorder les raccords de rinçage, de refroidissement et de vidange. Si le rinçage n'est pas requis, s'assurer que la garniture est bien fermée avec un bouchon de 1/4 NPT. S'assurer que la pompe est amorcée avant de la mettre en marche. Mettre les clips de centrage et les vis de côté. 	<p>Verificações anteriores à instalação.</p> <p>(i) Diâmetro externo do veio deve estar dentro dos limites de tolerância $\pm 0,002''$ ($\pm 0,05$ mm).</p> <p>(ii) Excentricidade do eixo $< 0,004''$ (0,1 mm). Leitura total do Indicador (T.I.R.).</p> <p>(iii) Folga axial do eixo $< 0,005''$ (0,13 mm).</p> <p>(iv) Certifique-se que o fluido fica vedado na face da caixa de buçim.</p> <p>(v) Devem ser eliminadas todas as arestas vivas sobre as quais deva passar o vedante "O" ring (2).</p> <p>Instruções para a instalação.</p> <ol style="list-style-type: none"> Lubrique o eixo com a massa lubrificante fornecida. Deslize o empanque sobre o eixo. Monte o resto do equipamento para ficar pronto a funcionar. Posicione o empanque. Monte sempre anilhas e aperte com muita firmeza as porcas dos pernos que vão fixar a flange do cartucho. Aperte de seguida os parafusos que fixam o empanque ao veio. Retire então os grampos centralizadores. Rode o veio manualmente e certifique-se de que não há nenhum ruído estranho, nem prisão de qualquer tipo, bem como nenhum empeno do próprio veio. Faça a ligação dos "Flushings," descarga, refrigeração e/ou drenagem segundo o que lhe foi aconselhado pelo seu técnico especializado. Os que não forem usados deverão ser tamponados com um bujão de rosca 1/4"NPT. Certifique-se de que ferrou a bomba antes de iniciar o seu funcionamento. Guarde os grampos e parafusos respectivos para utilização futura. Vão passar a ser necessários quando da próxima desmontagem 	<p>Kontrolle vóór montage:</p> <p>(i) De uitwendige asdiameter ligt binnen een tolerantie van $\pm 0,002''$ ($\pm 0,05$ mm.)</p> <p>(ii) De radiale speling is minder dan 0,004" (0,1 mm.)</p> <p>(iii) De axiale speling is minder dan 0,005" (0,13 mm.)</p> <p>(iv) De plaatpakking kan afdichten tegen de stopbuskamer</p> <p>(v) Vermijdt scherpe randen waarover de o-ring (pos.2) moet worden geschoven</p> <p>Montage-voorschriften</p> <ol style="list-style-type: none"> Smeer de as in met het meegeleverde (siliconen-)vet. Schuif de afdichting over de as. Bouw de rest van de installatie samen. Schuif de afdichting op z'n plaats. Gebruik in elk geval vlakke sluitringen en trek de flensmoeren stevig aan. Draai de meeneembouten (pos. 13) gelijkmatig vast op de as. Verwijder de centreerclips. (voor hergebruik bewaren). Draai de as handmatig rond. Luister en voel of de as niet aanloopt. Indien gewenst, sluit de spoel (flush), koel (quench) en aftap (drain) aan (1/4" NPT). Wanneer de flush-aansluiting niet gebruikt wordt zorg dan dat deze met een 1/4" NPT PLUG is afgedicht. Alvorens op te starten, zorg ervoor dat de pomp goed is gevuld en ontluicht. Centreerclips en schroeven voor hergebruik bewaren. 					
<p>Oversettelse av originale instruksjoner</p> <p>Kontroller før montering.</p> <p>(i) Akselens ytterdiameter er innen en toleranse på $\pm 0,05$ mm.</p> <p>(ii) Akselkast $< 0,1$ mm T.I.R.</p> <p>(iii) Akselens endeclaring $< 0,13$ mm.</p> <p>(iv) Væsketetning mot pakningsboksens flate.</p> <p>(v) O-ringen (2) må ikke gå over noen skarpe kanter.</p> <p>Monteringsanvisninger.</p> <ol style="list-style-type: none"> Smør akselen med fettet som følger med. Skyv tetningen inn på akselen. Sett resten av utstyret sammen i endelig driftstilling. Skyv tetningen på plass. Skiver må alltid monteres og glandmutrene må trekkes godt til. Trekk drivskruene jevnt og likt til mot akselen. Ta av innstillingsklemmene. Drei akselen for hånden. Lytt og føl om akselen "tar" noe sted. Koble til forbindelsene for spyling, kjøling og lufting. Dersom spyling ikke er nødvendig, vennligst tett anslutningen med en 1/4"NPT plugg. Se til at pumpen er primet før start. Ta vare på klemmene og klemmeskruene til senere bruk. 	NO	<p>Oversættelse af oprindelige brugsanvisning</p> <p>Kontrolforanstaltninger inden monteringen.</p> <p>(i) Den udvendige akseldiameter ligger indenfor toleranceområdet $\pm 0,002''$ ($\pm 0,05$mm)</p> <p>(ii) Akseludløb $< 0,004''$ (0,1mm) T.I.R.</p> <p>(iii) Aksial tolerance $< 0,005''$ (0,13mm).</p> <p>(iv) Der er adgang til vasketætningen på pakdåsebelægningen.</p> <p>(v) Der er ingen skarpe kanter for "O" tætningsringen (2) at passere.</p> <p>Monteringsvejledning.</p> <ol style="list-style-type: none"> Smør akslen med vedlagte smørefedt. Lad tætningen glide på plads på akslen. Monter resten af udstyret, så det er klar til drift. Lad tætningen glide på plads. Husk altid at bruge underlagsskiver og at fastspænde pakmøtrikkerne grundigt. Fastspænd monteringskruerne ligeligt ned over akslen. Fjern sætklemmerne. Drej akslen rundt med hånden. Kontroller at der ikke er akselbinding, osv. Tilslut eventuelle udskylnings-, køle- og afløbsforbindelser.Hvis skyllekanalen ikke anvendes, sørg for at hullet er forsvarligt afblændet med en 1/4"NPT prop. Sørg for at spæde pumpen inden den sættes i drift. Gem klemmerne og klemmeskruerne til senere brug. 	DK		<p>Käännös alkuperäisestä ohjeet</p> <p>Asennusta edeltävät tarkastukset.</p> <p>(i) Akselin ulkohalkasijan mittapoikkeama on enintään $\pm 0,05$mm.</p> <p>(ii) Akselin säteisyvälys on alle 0,1mm.</p> <p>(iii) Aksiaalinen välys on alle 0,13mm.</p> <p>(iv) Tiivisteiden runkolaipan tiiviste kohtaa tiivisteiden otsapinnan.</p> <p>(v) Akselilla ei ole teräviä kulmia, jotka voisivat vahingoittaa tiivisteiden o-rengasta (pos.2).</p> <p>Asennusohjeet</p> <ol style="list-style-type: none"> Voitele akseli mukana toimitetulla rasvalla. Työnnä tiiviste akselille. Kokoa laitteen muut osat lopullisiin paikkoihin. Työnnä tiiviste paikoilleen. Asenna aluslaatat kaikkiin pultteihin ja kiristä mutterit tiukkaan. Kiristä tiivisteiden lukitusruuvit tasaisesti akselille. Irrota asetuspidikkeet. Kierrä akselia käsin. Kuuntele ja tunnustelee varmistaksesi, että akseli pääsee pyörimään vapaasti. Kytke huuhtelu, tiivistevesi ja tyhjennysyhteys. Jos huuhteluyhteyttä ei tarvita, varmista, että huuhteluyhteys tulpataan 1/4" NPT tulpalla. Varmista, että pumpun esitäyttö on suoritettu ennen pumpun käynnistystä. Säilytä pidikkeet ja pidikkeiden ruuvit myöhempää käyttöä varten. 	FI	<p>Översättning av bruksanvisning i original</p> <p>Kontroller före installation.</p> <p>(i) Axelns ytterdiameter är inom toleransområdet $\pm 0,05$ mm ($\pm 0,002''$).</p> <p>(ii) Axelkast $< 0,1$ mm (0,004"), T.I.R. (total indikatoravläsning).</p> <p>(iii) Axialspel $< 0,13$ mm (0,005").</p> <p>(iv) Tätningsytan på packboxgaveln kontrolleras.</p> <p>(v) Att det inte finns några vassa kanter som O-tätningsringen (2) måste passera över.</p> <p>Installationsanvisningar.</p> <ol style="list-style-type: none"> Smörj axeln med medföljande fett. Skjut tätningen på axeln. Montera resten av utrustningen till färdigt skick. Skjut tätningen på plats. Drag fast glanderbultarna till slutligt moment Dra likformigt åt låsskruvarna mot axeln. Ta bort inställningsklammarna. (transportstöden) Rotera axeln för hand. Lyssna och känn efter om det är någon axelkärning etc. Koppla spol-, spär- och avtappningsanslutningarna. Om spolanslutningen inte behövs, se till att det är riktigt tätat med en 1/4"NPT plugg Se till att pumpens tätningsområde är luftat före start. Behåll klammarna och klammerskruvarna för senare användning. 	SE	